

## BLACKHAWK™

**Model 2620, Series 2**  
**Thermal Aerosol-Fog**  
**Petroleum-Based, Resonant Pulse Principle.**

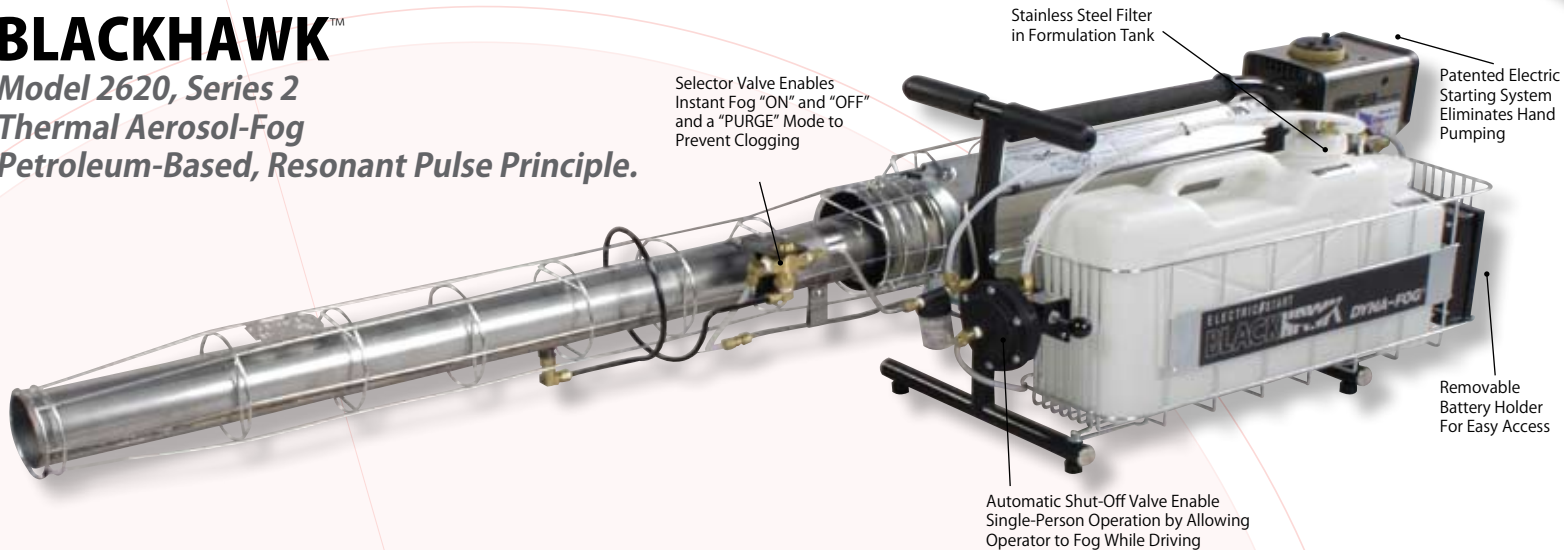

**The Blackhawk was designed for a wide range of jobs with maximum efficiency for handling petroleum-based products.**

The Blackhawk is capable of dispersing disinfectants, deodorizers, germicides and insecticides for application in greenhouses, a wide range of warehouses and for outdoor pest control in parks, gardens and golf courses.

The Blackhawk's simple, innovative design reduces unit maintenance and will provide years of rugged, reliable performance. Up to 18 gallons per hour capacity, rugged construction, easy maintenance and our patented electric starting system assures greater reliability, effectiveness, fuel efficiency and ease of operation. The machine is also equipped with an easy to clean stainless steel formulation filter that keeps the system free of unwanted dirt and residue.

### SPECIFICATIONS

Formulation Output:	0-18 gal/hr, or 0-68.4 liters/hr. Produces 114,000 cubic feet (3200 cubic meters) of effective output per minute
Engine Performance:	44 Hp, or 33KW
Fuel Consumption:	0.6 GPH or 2.3 liters/hr
Weight (Empty):	41 lbs. or 18.6 kg
Weight (Full):	75 lbs. or 34.1 kg
Fuel tank capacity:	0.5 gallon or 1.9 liters
Formulation Tank capacity:	3 gallons or 11.4 liters
Power Supply:	Eight 1.5 V "D" size alkaline batteries or a 12 VDC automobile cigarette lighter adapter.
Length:	68.3 in or 173.5 cm.
Width:	15 in or 38.1 cm
Height:	16.8 in or 42.7 cm
Fog Particle size:	0.5 - 50 microns

### DISTRIBUTED BY:

**CALL FOR YOUR NEAREST DISTRIBUTOR**

317.896.2561  
 317.896.3788 FAX  
 INFO@DYNAFOG.COM

### SHIPPING DATA:

L x W x H: 71 x 19 x 20 (in) or 180 x 48 x 54 (cm)  
 Weight: 73 lbs. or 33.11 kg  
 Drum Kit: 8 lbs. or 3.6 kg  
 Volume: 15.61Cu. Ft or 0.44 cu. M.;



**ONE YEAR LIMITED WARRANTY**