

BLACKHAWK ELECTRIC START

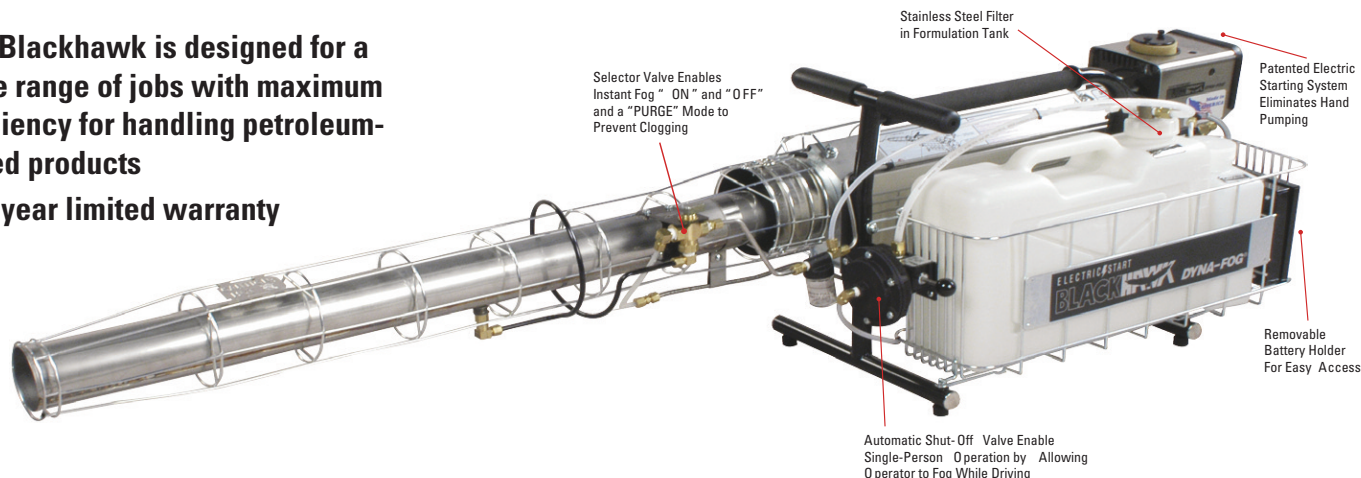

Thermal Aerosol-Fog Petroleum-Based, Resonant Pulse Principle

- The Blackhawk is designed for a wide range of jobs with maximum efficiency for handling petroleum-based products
- One year limited warranty



For Professional Use

The Blackhawk was designed for a wide range of jobs with maximum efficiency for handling petroleum-based products. The Blackhawk is capable of dispersing disinfectants, deodorizers, germicides and insecticides for application in greenhouses, a wide range of warehouses and for outdoor pest control in parks, gardens and golf courses.

The Blackhawk's simple, innovative design reduces unit maintenance and will provide years of rugged, reliable performance. Up to 18 gallons per hour capacity, rugged construction, easy maintenance and our patented electric starting system assures greater reliability, effectiveness, fuel efficiency and ease of operation. The machine is also equipped with an easy to clean stainless steel formulation filter that keeps the system free of unwanted dirt and residue.

Part #	Description
86550	Blackhawk Electric Start 2620, Series 2
86550-20	Blackhawk Electric Start Series 2

SPECIFICATIONS

Formulation Output:	0-18 gal/hr, or 0-68.4 liters/hr. Produces 114,000 cubic feet (3200 cubic meters) of effective output per minute
Engine Performance:	44 Hp, or 33KW
Fuel Consumption:	0.6 GPH or 2.3 liters/hr
Weight (Empty):	41 lbs. or 18.6 kg
Weight (Full):	75 lbs. or 34.1 kg
Fuel Tank Capacity:	0.5 gallon or 1.9 liters
Formulation Tank Capacity:	3 gallons or 11.4 liters
Power Supply:	Eight 1.5 V "D" size alkaline batteries or a 12 VDC automobile cigarette lighter adapter.
Length:	68.3 in or 173.5 cm.
Width:	15 in or 38.1 cm
Height:	16.8 in or 42.7 cm
Fog Particle size:	0.5 - 50 microns

SHIPPING DATA:

L x W x H: 71 x 19 x 20 (in) or 180 x 48 x 54 (cm)
 Weight: 73 lbs. or 33.11 kg
 Drum Kit: 8 lbs. or 3.6 kg
 Volume: 15.61Cu. Ft or 0.44 cu. M.;

SALES AND TECHNICAL SUPPORT
 135 Region South Drive
 Jackson GA 30233
 678-688-5601
www.bgequip.com



Curtis Dyna-Fog a Division of B&G Equipment Company

MANUFACTURING FACILITY
 525 Park Street
 Westfield, IN 46074
www.dynafog.com